



PIKRAKIS

ALUMINIUM INDUSTRY



- 2 Η ΕΤΑΙΡΙΑ ΠΙΚΡΑΚΗΣ / ΠΙΚΡΑΚIS S.A. / ΠΙΚΡΑΚIS S.A.
- 3 ΠΙΣΤΟΠΟΙΗΜΕΝΗ ΠΟΙΟΤΗΤΑ / CERTIFIED QUALITY / UNE QUALITÉ CERTIFIÉE
- 4 ΚΑΓΚΕΛΑ ΑΠΟ ΜΑΣΙΦ ΑΛΟΥΜΙΝΙΟ / SOLID ALUMINUM RAILS / BARREAUX EN ALUMINIUM MASSIF
- 11 ΣΥΜΒΑΤΙΚΑ ΚΑΓΚΕΛΑ / CONVENTIONAL RAILS / BARREAUX EN ALUMINIUM
- 22 ΑΣΦΑΛΕΙΕΣ / SAFETIES / GRILLE DE SÉCURITÉ
- 23 ΚΑΓΚΕΛΟ ΣΚΑΛΑΣ / STAIR RAIL SYSTEM / BARREAU D'ESCALIER
- 24 ΑΥΛΟΓΥΡΟΣ / FENCE / CLÔTURES
- 29 ΚΑΓΚΕΛΟΠΟΡΤΕΣ, ΓΚΑΡΑΖΟΠΟΡΤΑ / GATES, GARAGE DOORS / PORTAILS, PORTE DE GARAGE
- 37 ΑΝΟΔΙΩΜΕΝΑ ΚΑΓΚΕΛΑ / ANODIZED ALUMINUM RAILINGS / BARREAUX ANODISÉS
- 47 ΣΤΕΓΑΣΤΡΑ ΕΙΣΟΔΟΥ / DOOR CANOPIES / MARQUISES
- 48 ΠΕΡΓΚΟΛΑ / PERGOLA / PERGOLA
- 52 ΦΩΤΙΣΤΙΚΑ / LIGHTINGS / LUMINAIRES
- 58 ΚΟΥΦΩΜΑΤΑ / FRAMES / FENÊTRES

Η εταιρία Πικράκης ΑΕ έχει διαγράψει μια επιτυχημένη και συνεχώς εξελισσόμενη πορεία στον κλάδο του αλουμινίου από το 1995.

Σήμερα πλέον, είναι μια ισχυρή καθιερωμένη μονάδα παραγωγής και βαφής προϊόντων αλουμινίου με τοπική και διεθνή παρουσία, με επιτυχημένες συνεργασίες σε Ευρώπη, Αφρική, Καραϊβική και Αραβικές χώρες.

Ο άψογος συνδυασμός της τεχνογνωσίας, ο μηχανολογικός εξοπλισμός και το καταρτισμένο προσωπικό, έχουν σαν αποτέλεσμα την δυνατότητα κατασκευής οποιουδήποτε προϊόντος αλουμινίου σύμφωνα με τις ιδιαίτερες απαιτήσεις του πελάτη και ανάγκες του χώρου σε μεγάλες ποσότητες.

Pikrakis S.A. has had a successful history in the aluminum sector since 1995, marked by constant growth.

Today it is a vertical aluminum product manufacturing and coating plant with a strong local and international presence and successful partnerships in Europe, Africa, the Caribbean and Arab countries.

The excellent combination of know-how, mechanical equipment and trained staff enables us to manufacture large quantities of any aluminum product, according to our clients' specification and the requirements of each area.

La société Pikrakis SA a fait preuve, depuis 1995, d'un parcours fait de réussites et de progrès ininterrompus dans le secteur de l'aluminium.

Elle est aujourd'hui une unité forte, intégrée verticalement, de production et de laquage des matériaux aluminium, présente aussi bien sur le marché intérieur qu'à l'étranger, et collabore avec succès avec des pays de l'Europe, de les Caraïbes, de l'Afrique et de l'Arabie.

L'alliance parfaite du savoir-faire, de l'équipement mécanique et du personnel qualifié, permettent la conception de n'importe quel matériau aluminium conformément aux exigences spécifiques du client et des spécifications du lieu, et ce en de grandes quantités.





Πιστοποιημένη ποιότητα

Το βαφείο της Πικράκης ΑΕ έχει την δυνατότητα να κάνει ειδική επεξεργασία πριν την βαφή, για μεγαλύτερη αντοχή στην διάβρωση. Η προεργασία αυτή συνιστάται για ιδιαίτερα επιβαρυσμένα από ρύπους και παραθαλάσσια περιβάλλοντα.

Η εταιρία εφαρμόζει σύστημα Διαχείρισης Ποιότητας σύμφωνα με το πρότυπο EN ISO 9001:2015, Factory production Control (fpc) και διαθέτει στην αγορά κουφώματα με σήμανση CE.



Certified quality

The coating plant of Pikrakis S.A. is able to apply special treatments before coat-ing the product, to ensure higher corrosion resistance. This pre-treatment is recommended for environments that are especially affected by pollutants or are located close to the sea.

The company implements a Quality Management System according to EN ISO 9001:2015, Factory Production Control (FPC) and markets CE-marked frames.



Une qualité certifiée

L'unité de laquage de la société Pikrakis SA peut réaliser un traitement spécifique avant le laquage, pour une meilleure résistance à la corrosion. Cette préparation est recommandée dans les environnements particulièrement pol-lués ou situés en bord de mer.

La société met en oeuvre le système de gestion de la qualité, conformément à la norme EN ISO 9001:2015, Factory production Control (fpc) et commercialise des fenêtres portant le marquage CE.





الجزيرة
THE PEARL

QATAR قطر

Κάγκελα από μασίφ αλουμίνιο

Η εταιρεία μας κατασκεύασε 800 αυλό-πορτες και 7.8χλμ αυλόγυρο μασίφ αλουμινίου για το τεχνητό νησί Pearl, το τεχνητό μαργαριτάρι του Qatar. Το έργο αυτό αποτέλεσε την γέννηση της σειράς μασίφ κικλιδωμάτων.

Solid aluminum rails

Our company constructed 800 yard doors and a 7.8-km fence of solid aluminum for the artificial island Pearl, the artificial pearl of Qatar. This project gave birth to the solid aluminum rail line.

Barreaux en aluminium massif

Notre société a conçu 800 portails et 7,8 km de clôture pour l'île artificielle Pearl, au Qatar. Cet ouvrage a marqué le lancement de notre gamme de grilles en aluminium massif.



Η σειρά αυτή, έρχεται να καλύψει ένα κενό στην διεθνή αγορά, αφού καταφέρνει να συνδυάσει την αισθητική του σιδήρου με την αντοχή του αλουμινίου. Το πλέον δυνατό χαρακτηριστικό της είναι η απεριόριστη γκάμα σχεδίων.

Σας παραθέτουμε ορισμένα σχέδια, εκ των οποίων τα περισσότερα δημιουργήθηκαν βάσει σχεδίου πελάτη.

Φυσικά το κάθε σχέδιο γίνεται κάγκελο, αυλόγυρος, ασφάλεια και καγκελόπορτα.

This line fills a gap there was in the international market, since it manages to combine the aesthetics of iron and the strength of aluminum. Its strongest feature is the unlimited range of designs.

You can find some of the designs below; most of them were custom-made.

Of course, each design can be applied to railing, fences, window safety bars and gates.

Cette gamme est destinées à combler une lacune sur le marché mondial, alliant l'esthétisme du fer à l'endurance de l'aluminium. Son point fort est le nombre illimité de formes qu'elle autorise.

Nous vous présentons ici quelques modèles, dont la plupart sont le fruit des plans de nos clients.

Chaque modèle peut, bien sûr, convenir pour des barreaux, une clôture, une grille de sécurité ou un portail.





R105 | 30-110cm



R107 | 30-110cm



R108 | 30-110cm



R130 | 30-110cm



R132 | 30-110cm



R106 | 30-110cm



- » Το επιθυμητό ύψος επιτυγχάνεται με την αυξομείωση του πάνω και κάτω κενού, όπως επίσης και των κάθετων γραμμών.
- » The desired height is achieved by increasing and decreasing the gap on the top and the bottom as well as the vertical lines.
- » La hauteur désirée est obtenue par le réglage de la taille de l'espace libre en-dessous et au-dessus, ainsi que des barres verticales.



R123 | 30-110cm



R124 | 50-110cm



R103 | 30-110cm

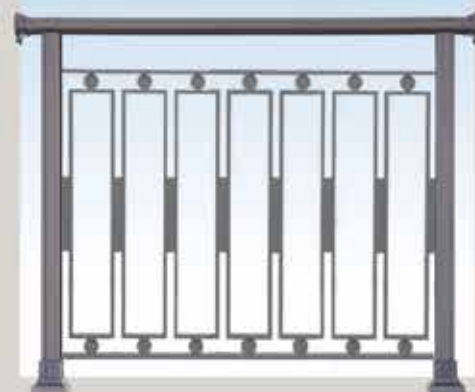

R101 | 40-110cm

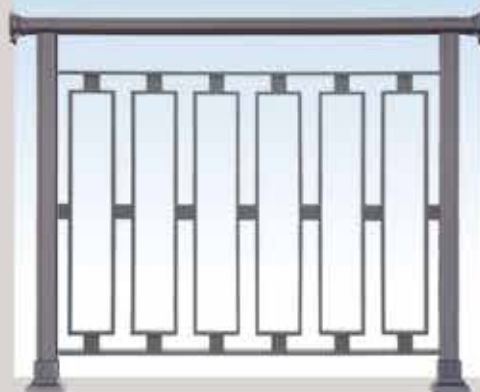

R102 | 40-110cm



R134 | 60-100cm

» Το επιθυμητό ύψος επιτυγχάνεται με την αυξομείωση του πάνω και κάτω κενού, όπως επίσης και των κάθετων γραμμών.

» The desired height is achieved by increasing and decreasing the gap on the top and the bottom as well as the vertical lines.

» La hauteur désirée est obtenue par le réglage de la taille de l'espace libre en-dessous et au-dessus, ainsi que des barres verticales.



R109 | 40-110cm



R113 | 40-110cm



R114 | 60-110cm



R110 | 50-110cm



R118 | 50-110cm



R136 | 100cm

- » Το επιθυμητό ύψος επιτυγχάνεται με την αυξομείωση του πάνω και κάτω κενού, όπως επίσης και των κάθετων γραμμών.
- » The desired height is achieved by increasing and decreasing the gap on the top and the bottom as well as the vertical lines.
- » La hauteur désirée est obtenue par le réglage de la taille de l'espace libre en-dessous et au-dessus, ainsi que des barres verticales.



R126 | 60-110cm



R116 | 60-110cm



R127 | 60-110cm



R137 | 60-90cm



R138 | 60-100cm



R115 | 60-110cm

- » Το επιθυμητό ύψος επιτυγχάνεται με την αυξομείωση του πάνω και κάτω κενού, όπως επίσης και των κάθετων γραμμών.
- » The desired height is achieved by increasing and decreasing the gap on the top and the bottom as well as the vertical lines.
- » La hauteur désirée est obtenue par le réglage de la taille de l'espace libre en-dessous et au-dessus, ainsi que des barres verticales.



R145 | 40-110cm



R128 | 40-110cm



R144 | 30-110cm



R129 | 30-110cm

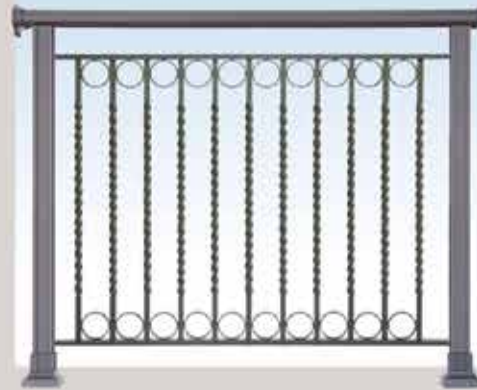

R125 | 40-110cm



R143 | 40-110cm

» Το επιθυμητό ύψος επιτυγχάνεται με την αυξομείωση του πάνω και κάτω κενού, όπως επίσης και των κάθετων γραμμών.

» The desired height is achieved by increasing and decreasing the gap on the top and the bottom as well as the vertical lines.

» La hauteur désirée est obtenue par le réglage de la taille de l'espace libre en-dessous et au-dessus, ainsi que des barres verticales.

tip!

Να μην τοποθετείται σε χώρους που έχουν πρόσβαση μικρά παιδιά.

Do not install where small children can access it.

Ne convient pas aux lieux accessibles par des petits enfants.



Κωδ. / Code / Référence
01



Κωδ. / Code / Référence 19-06
Υψος / Height / hauteur 28-43cm

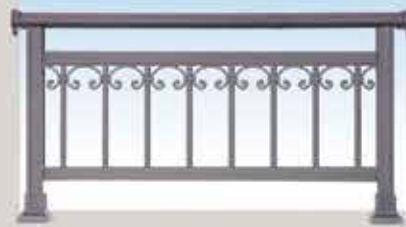

Κωδ. / Code / Référence 35-03
Υψος / Height / hauteur 45-60cm



Κωδ. / Code / Référence 55-05
Υψος / Height / hauteur 67-80cm



Κωδ. / Code / Référence 70-13
Υψος / Height / hauteur 82-95cm



Κωδ. / Code / Référence 80-23
Υψος / Height / hauteur 92-105cm



Σκάλα/ Stairs/ barreau d'escalier



Αυλόπορτα/ Gate/ portail



Αυλόγυρος / Fence / clôture



/ Ασφάλεια
/ Security S1300
/ grille de sécurité

CODE K501 - K506

ΚΩΔ. / COD	ΥΨΟΣ / HEIGHT (cm)
K501	<30
K502	31-48
K503	49-60
K504	61-73
K505	74-85
K506	86-100

tip!

Να μην τοποθετείται σε χώρους που έχουν πρόσβαση μικρά παιδιά.

Do not install where small children can access it.

Ne convient pas aux lieux accessibles par des petits enfants.

CODE 400

ΚΩΔ. / COD	ΥΨΟΣ / HEIGHT (cm)
35-400	48-60
45-400	58-70
55-400	68-80
65-400	78-90
75-400	88-100

AVANT GARDE



ROUND	ΚΩΔ. / COD	ΥΨΟΣ / HEIGHT (cm)
ΧΩΡΙΣ ΟΡΙΖΟΝΤΙΟ ΣΩΛΗΝΑΚΙ NO HORIZONTAL PIPE SANS TUBE HORIZONTAL	K460-101	50-66
ΟΡΙΖΟΝΤΙΟ ΣΩΛΗΝΑΚΙ X1 HORIZONTAL PIPE X1 TUBE HORIZONTAL X1	K480-101	75-85
ΟΡΙΖΟΝΤΙΟ ΣΩΛΗΝΑΚΙ X2 HORIZONTAL PIPE X2 TUBE HORIZONTAL X2	K4100-101	95-105

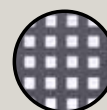

RECTANGULAR	ΚΩΔ. / COD	ΥΨΟΣ / HEIGHT (cm)
ΧΩΡΙΣ ΟΡΙΖΟΝΤΙΟ ΣΩΛΗΝΑΚΙ NO HORIZONTAL PIPE SANS TUBE HORIZONTAL	K460-102	50-66
ΟΡΙΖΟΝΤΙΟ ΣΩΛΗΝΑΚΙ X1 HORIZONTAL PIPE X1 TUBE HORIZONTAL X1	K480-102	75-85
ΟΡΙΖΟΝΤΙΟ ΣΩΛΗΝΑΚΙ X2 HORIZONTAL PIPE X2 TUBE HORIZONTAL X2	K-4100-102	95-105

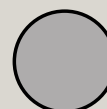

GLASS	ΚΩΔ. / COD	ΥΨΟΣ / HEIGHT (cm)
ΧΩΡΙΣ ΟΡΙΖΟΝΤΙΟ ΣΩΛΗΝΑΚΙ NO HORIZONTAL PIPE SANS TUBE HORIZONTAL	K460-301	50-66
ΟΡΙΖΟΝΤΙΟ ΣΩΛΗΝΑΚΙ X1 HORIZONTAL PIPE X1 TUBE HORIZONTAL X1	K480-301	75-85
ΟΡΙΖΟΝΤΙΟ ΣΩΛΗΝΑΚΙ X2 HORIZONTAL PIPE X2 TUBE HORIZONTAL X2	K4100-301	95-105



CODE 100



ΚΩΔ. / COD	ΥΨΟΣ / HEIGHT (cm)
35-100	48-60
45-100	58-70
55-100	68-80
65-100	78-90
75-100	88-100
85-100	100-110

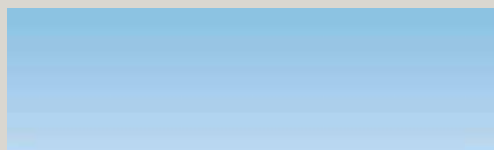

LINEAR 828



ΚΩΔ. / COD	ΥΨΟΣ / HEIGHT (cm)
35-828	45-60
55-828	67-80
70-828	82-95
80-828	92-105
90-828	105-115

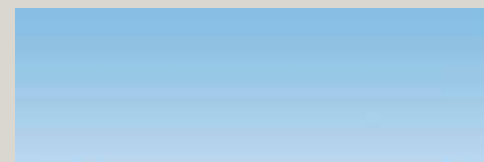

OLYMPIC



ΚΩΔ. / COD	ΥΨΟΣ / HEIGHT (cm)
35-15	45-60
55-15	67-80
70-37	82-95
80-19	92-105
90-828	105-115

/ Οι παραπάνω κωδικοί είναι διαθέσιμοι σε όλες τις κατηγορίες του προϊόντος
 / The codes above are available for all product categories
 / Les produits aux références mentionnées ci-dessus sont disponibles dans toutes les catégories de produit

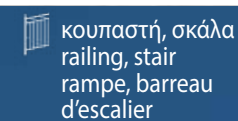



CODE 300



ΚΩΔ. / COD	ΥΨΟΣ / HEIGHT (cm)
35-300	48-60
45-300	58-70
55-300	68-80
65-300	78-90
75-300	88-100



CODE 200



ΚΩΔ. / COD	ΥΨΟΣ / HEIGHT (cm)
55-200	68-80
65-200	78-90
75-200	88-100



CODE 700



ΚΩΔ. / COD	ΥΨΟΣ / HEIGHT (cm)
35-700	48-60
45-700	58-70
55-700	68-80
65-700	78-90
75-700	88-100



ETHNIKIS



ΚΩΔ. / COD	ΥΨΟΣ / HEIGHT (cm)
19-02	28-43
35-06	46-60
55-03	67-80
70-11	82-95
80-01	92-105

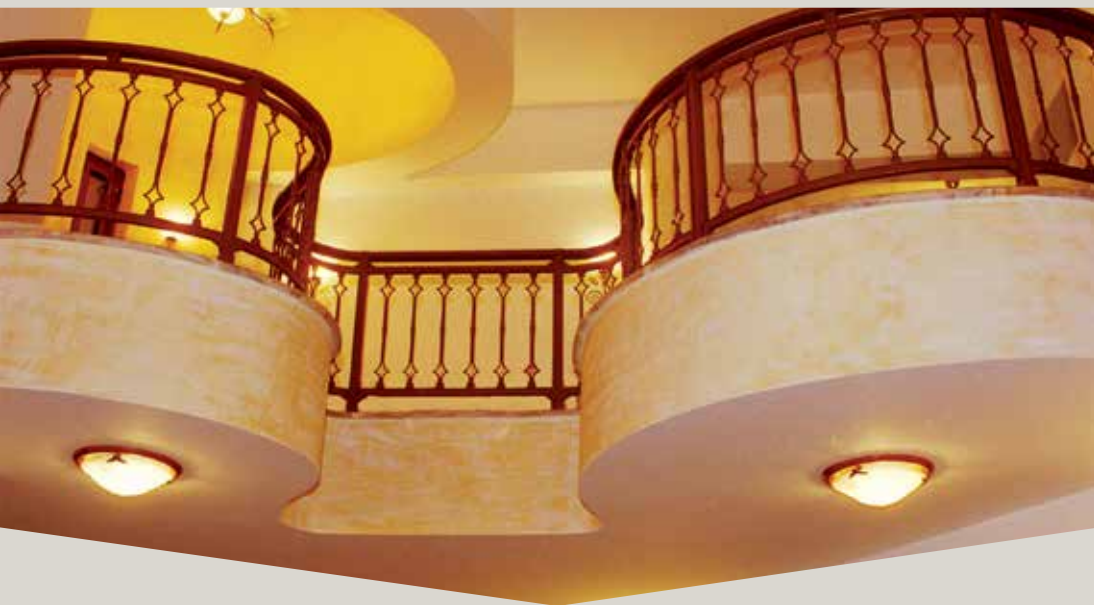

ASTERI



ΚΩΔ. / COD	ΥΨΟΣ / HEIGHT (cm)
15-00	28-40
35-14	45-60
55-17	67-80
70-36	82-95
80-18	92-105

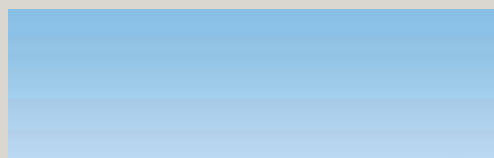

ASTERI DOUBLE



ΚΩΔ. / COD	ΥΨΟΣ / HEIGHT (cm)
35-16	45-60
55-16	67-80
70-34	82-95
80-10	92-105



KIKLADITIKO



ΚΩΔ. / COD	ΥΨΟΣ / HEIGHT (cm)
35-17	45-60
55-18	67-80
70-33	82-95
80-22	92-105

/ Οι παραπάνω κωδικοί είναι διαθέσιμοι σε όλες τις κατηγορίες του προϊόντος
 / The codes above are available for all product categories
 / Les produits aux références mentionnées ci-dessus sont disponibles dans toutes les catégories de produit

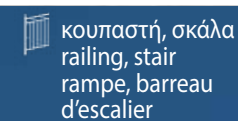
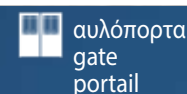

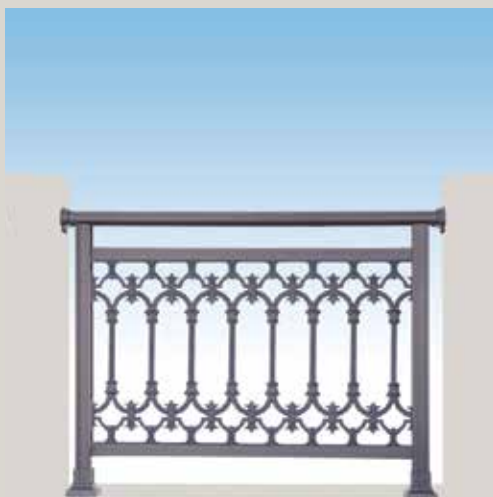

VIENNA

ΚΩΔ. / COD	ΥΨΟΣ / HEIGHT (cm)
35-02	45-60
55-01	67-80
70-24	82-95
80-24	92-105

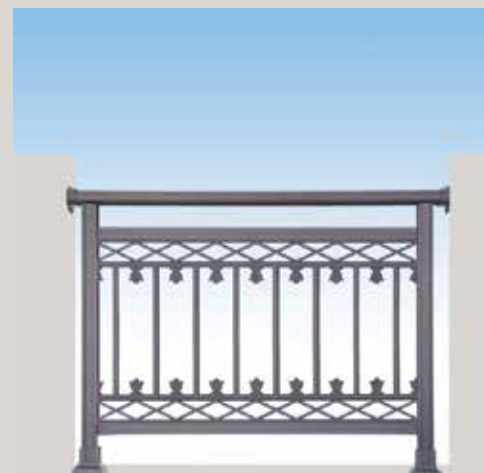

ΚΟΛΟΝΑΤΟ

ΚΩΔ. / COD	ΥΨΟΣ / HEIGHT (cm)
35-04	46-60
55-04	67-80
70-01	82-95
80-24	92-105

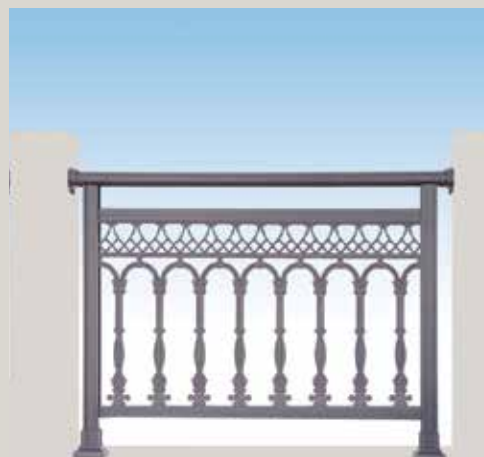

ΚΑΜΑΡΑ

ΚΩΔ. / COD	ΥΨΟΣ / HEIGHT (cm)
16-04	25-40
35-01	46-60
55-02	67-80
70-12	82-95

GARLAND



ΚΩΔ. / COD	ΥΨΟΣ / HEIGHT (cm)
15-03	25-40
35-07	45-60
55-07	67-80
70-26	82-95

ATHINAIKO

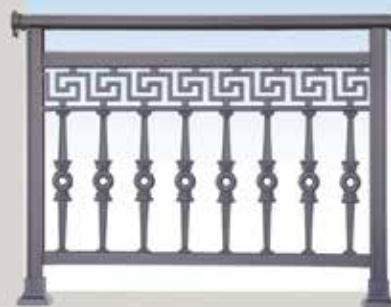

ΚΩΔ. / COD	ΥΨΟΣ / HEIGHT (cm)
18-01	28-43
35-05	45-60
55-08	67-80
70-25	82-95

KNOSOS

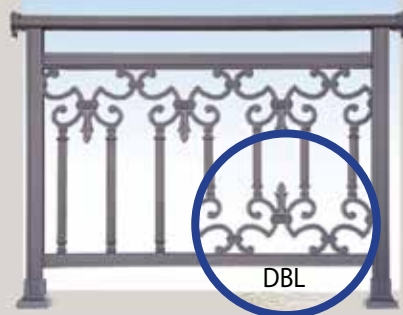

ΚΩΔ. / COD	ΥΨΟΣ / HEIGHT (cm)
35-09	45-60
50-01	67-80
70-29	82-95
70-31 -DBL	82-95
80-07	92-105
80-09 -DBL	92-105

FESTOS



ΚΩΔ. / COD	ΥΨΟΣ / HEIGHT (cm)
50-02	58-74
70-30	82-95
80-08	92-105

/ Οι παραπάνω κωδικοί είναι διαθέσιμοι σε όλες τις κατηγορίες του προϊόντος
 / The codes above are available for all product categories
 / Les produits aux références mentionnées ci-dessus sont disponibles dans toutes les catégories de produit

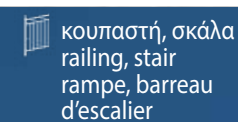

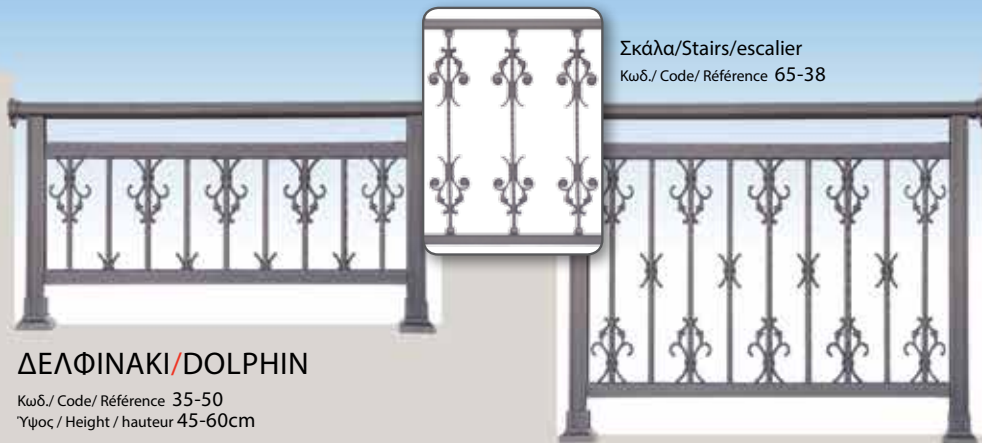

Σκάλα/Stairs/escalier
Κωδ./ Code/ Référence 65-38

ΔΕΛΦΙΝΑΚΙ/DOLPHIN

Κωδ./ Code/ Référence 35-50
Υψος / Height / hauteur 45-60cm

ΔΕΛΦΙΝΑΚΙ/DOLPHIN

Κωδ./ Code/ Référence 70-14
Υψος / Height / hauteur 82-95cm

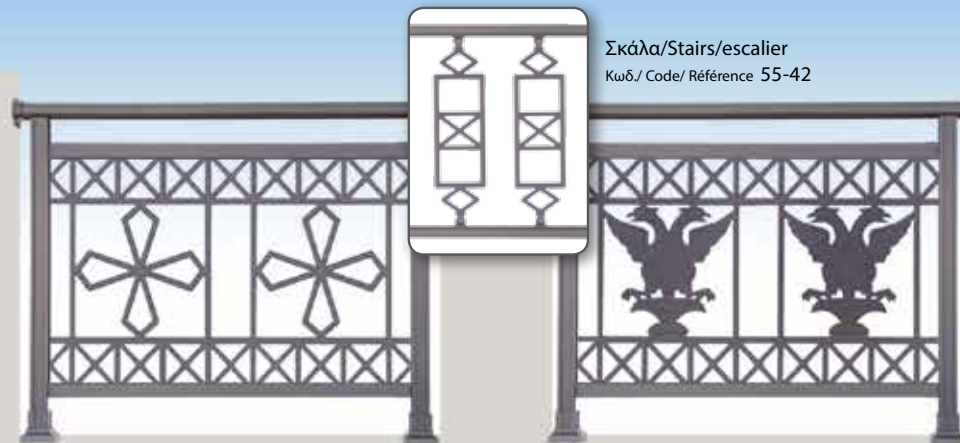

Σκάλα/Stairs/escalier
Κωδ./ Code/ Référence 55-42

ΣΤΑΥΡΟΣ/CROSS

Κωδ./ Code/ Référence 70-22
Υψος / Height / hauteur 82-95cm

ΔΙΚΕΦΑΛΟΣ/DIKEFALOS

Κωδ./ Code/ Référence 70-23
Υψος / Height / hauteur 82-95cm



ΡΟΖΕΤΑ/ROZETTE

Κωδ./ Code/ Référence 17-07
Υψος / Height / hauteur 27-42cm



ΓΛΑΣΤΡΑ/FLOWERPOT

Κωδ./ Code/ Référence 70-21
Υψος / Height / hauteur 82-95cm



ΠΕΡΙΚΟΚΛΑΔΑ/PERIKOKLADA

Κωδ./ Code/ Référence 70-20
Υψος / Height / hauteur 82-95cm



ΧΙΑΣΤΙ / CHIASTI

Κωδ./ Code/ Référence 14-05
Υψος / Height / hauteur 22-38cm



ΧΙΑΣΤΙ / CHIASTI

Κωδ./ Code/ Référence 35-11
Υψος / Height / hauteur 45-60cm



ΧΙΑΣΤΙ / CHIASTI

Κωδ./ Code/ Référence 55-14
Υψος / Height / hauteur 67-80cm



ΒΕΝΤΑΛΙΑ / VEDALIA

Κωδ./ Code/ Référence 35-12
Υψος / Height / hauteur 45-60cm



ΒΕΝΤΑΛΙΑ / VEDALIA

Κωδ./ Code/ Référence 55-12
Υψος / Height / hauteur 45-60cm





ΓΡΑΜΜΙΚΟ/LINEAR

Κωδ./ Code/ Référence 70-10
Υψος / Height / hauteur 82-95cm



ΑΓΚΥΡΑ/ANCHOR

Κωδ./ Code/ Référence 70-18
Υψος / Height / hauteur 82-95cm



ΠΗΔΑΛΙΟ/WHEEL

Κωδ./ Code/ Référence 70-19
Υψος / Height / hauteur 82-95cm

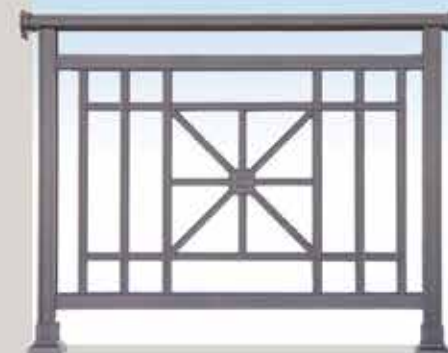

ΚΛΑΣΙΚΟ/CLASIC

Κωδ./ Code/ Référence 70-16
Υψος / Height / hauteur 82-95cm

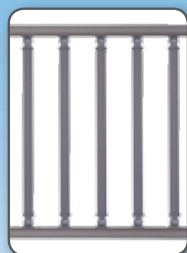

Σκάλα/Stairs/escalier
Κωδ./ Code/ Référence
Γραμμικό-Linear



ΠΑΛΕΡΜΟ/PALERMO

Κωδ./ Code/ Référence 80-20
Υψος / Height / hauteur 92-105cm



ΕΦΕΣΣΟΣ/EFESSOS

Κωδ./ Code/ Référence 80-14
Υψος / Height / hauteur 92-105cm



ΑΜΦΟΡΕΑΣ/AMPHOREAS

Κωδ./ Code/ Référence 80-15
Υψος / Height / hauteur 92-105cm



ΓΕΩΜΕΤΡΙΚΟ/GEOMETRICO

Κωδ./ Code/ Référence 80-21
Υψος / Height / hauteur 92-105cm

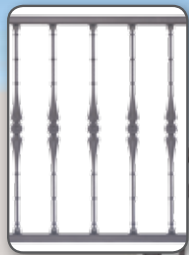

Σκάλα/Stairs/escalier
Κωδ./ Code/ Référence 85-48



ΒΕΝΕΤΣΙΑΝΙΚΟ/ VENETIAN

Κωδ./ Code/ Référence 70-15
Υψος/ Height / hauteur 82-95cm



Σκάλα/Stairs/escalier
Κωδ./ Code/ Référence 85-46



ΑΠΟΙΚΙΑΚΟ/ COLONIAL

Κωδ./ Code/ Référence 80-05
Υψος/ Height / hauteur 92-105cm



Σκάλα/Stairs/escalier
Κωδ./ Code/ Référence 85-47



ΓΡΑΜΜΙΚΟ/ LINEAR

Κωδ./ Code/ Référence 80-03
Υψος/ Height / hauteur 92-105cm

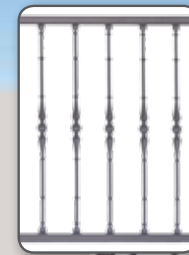

Σκάλα/Stairs/escalier
Κωδ./ Code/ Référence 85-46



ΜΙΝΩΙΚΟ Α/ MINOAN A

Κωδ./ Code/ Référence 80-11
Υψος/ Height / hauteur 92-105cm



ΓΟΤΘΙΚΟ/ GOTHIC

Κωδ./ Code/ Référence 19-09
Υψος/ Height / hauteur 28-43cm

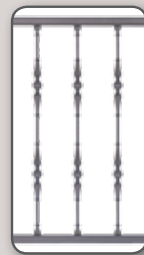

Σκάλα/Stairs/escalier
Κωδ./ Code/ Référence 85-47



ΓΟΤΘΙΚΟ/ GOTHIC

Κωδ./ Code/ Référence 80-04A
Υψος/ Height / hauteur 92-105cm



ΓΟΤΘΙΚΟ/ GOTHIC

Κωδ./ Code/ Référence 70-38
Υψος/ Height / hauteur 82-95cm



ΓΟΤΘΙΚΟ/ GOTHIC

Κωδ./ Code/ Référence 80-04
Υψος/ Height / hauteur 92-105cm



S1006



S1300

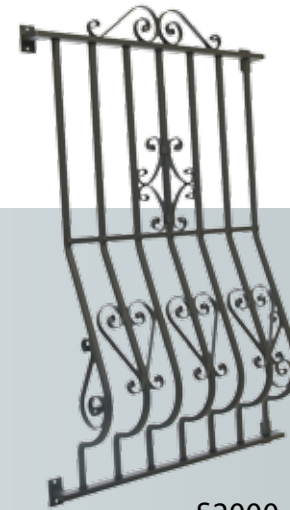

S2000



S2001



S3000



S1006B



ΚΑΓΚΕΛΟ ΣΚΑΛΑΣ / STAIR RAIL SYSTEM / BARREAU D'ESCALIER



ΡΟΚΑ/ROKA | 55-39



ΚΡΙΝΟΣ/KRINOS | 55-41



ΑΠΕΡΙΤΟ/APERITO | 65-31



ΚΑΡΑΒΟΛΟ/KARAVOLO | 65-32



ΣΑΪΤΑ/SAITA | 65-34



ΣΤΡΙΦΤΟ/STRIFTO | 75-39



ΤΟΥΛΙΠΑ/TULIP | 75-40



ΡΩΜΑΪΚΟ/ROMAN | 75-32



ΑΓΙΟΚΛΙΜΑ/ΑΥΓΙΟΚΛΙΜΑ | A85-30



ΛΟΥΒΡΟ/LOUVRE | A85-31



ΜΙΝΟΑΝ-Α | A85-46



ΜΙΝΟΑΝ-Β | A85-47



ΗΛΙΟΣ/SUN | A85-48



ΔΗΛΟΣ/DILOS | A85-49



ΣΑΪΤΑ/SAITA | 85-42



ΒΕΛΟΣ/ARROW | 85-43

tip!

Επιλέξτε λόγχη για τα σχέδια των σελίδων 25-35

Select a spear top picket for the designs of the pages 25-35

Choisissez la pointe de lance pour les modèles des pages 25-35



16-22



19-10



16-11



13-13

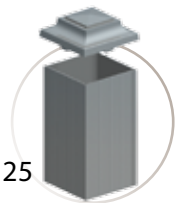

25

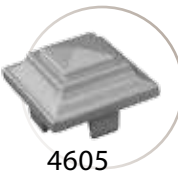

4605

Η κολώνα αυτή μπορεί να χρησιμοποιηθεί σε μεγάλα ανοίγματα (σε κάγκελα και αυλόγυρο) για επιπλέον στήριξη. Μεγάλο ή μικρό άνοιγμα, η κολώνα αυτή με θυρό ή τάπα (4605) προσδίδει ένα ιδιαίτερο καλαίσθητο ύφος.

This column can be used in large openings (in railings and fences) for additional support. Whether the opening is large or small, this column with a thyrse or a fitting (4605) gives a special, tasteful style.

Cette colonne peut être utilisée pour de grandes ouvertures (en barreaux et clôtures), pour un meilleur support. Pour ouverture importante ou réduite, cette colonne surmontée d'un ornement ou d'un chapiteau (4605) offre une note esthétique particulière.

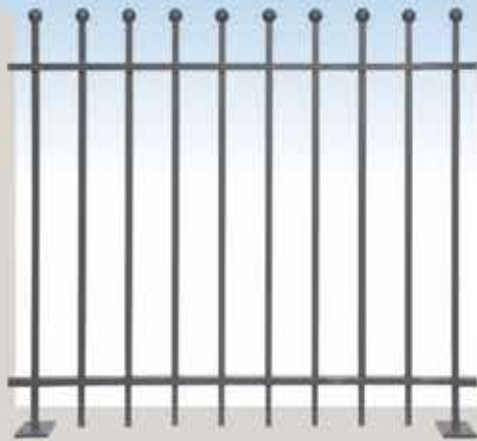

F1000

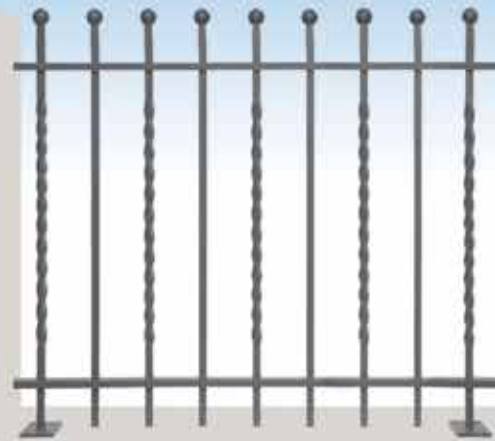

F1009



F1300

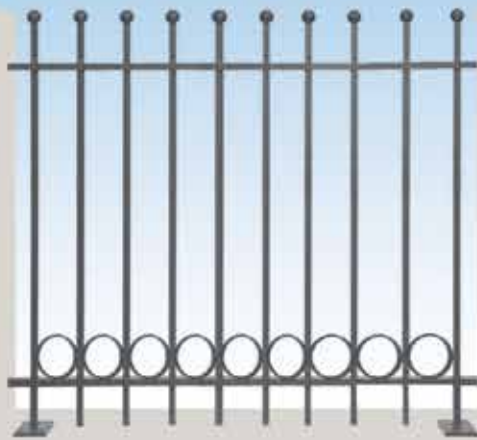

F1006



F1003



F1002



F1004B

Οι καλαίσθητοι φράχτες αλουμινίου διακρίνονται για την υψηλή αισθητική και τον προσεγμένο σχεδιασμό τους. Περιβάλλουν την αυλή του σπιτιού σας με τον πλέον όμορφο τρόπο και την προστατεύουν από τους ανεπιθύμητους επισκέπτες.

The elegant aluminum fences stand out for their aesthetics and careful design. They surround your house yard in the most beautiful way and protect it from unwanted visitors.

Nos élégantes clôtures en aluminium se distinguent par leur caractère hautement esthétique et leur conception soignée. Elles délimiteront le pourtour de la cour de votre maison de la plus belle manière, tout en vous préservant des visiteurs indésirables.

gp 511 oval



gp 512



89-01

gp 518





G026



G002



G202



G5007

Το τυφλό μέρος την καγκελόπορτας μπορεί να γίνει με:

- 1. Προφίλ αλουμινίου
- 2. Επίπεδη λαμαρίνα,
 - 2.1 Κορνίζα
 - 2.2 Κορνίζα περτσίνια
- 3. Λαμαρίνα πυραμίδα

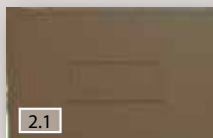

The blind part of the gate can be constructed using:

- 1. An aluminum profile
- 2. A flat metal sheet
 - 2.1 A frame
 - 2.2 A frame and rivets
- 3. A pyramidal metal sheet

La partie pleine du portail peut être constituée de :

- 1. Profilé aluminium
- 2. Tôle plane
 - 2.1 Encadrement
 - 2.2 Encadrement grille
- 3. Tôle pyramidale



G307



G308



G303



G1036



G028



G014



G027



G107



G024



G025

- Όλες οι καγκελόπορτες λειτουργούν και με μηχανισμό.
- All gates also work using an electrical mechanism
- Tous nos portails peuvent également fonctionner grâce à un mécanisme automatique



G012



G010



G020



G021



G1020



G1030



G600



G035

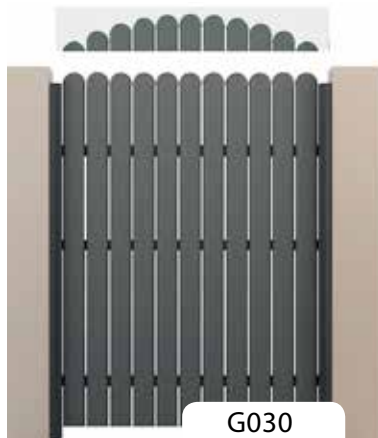

G030



G1090



G512



G1099



G1010



G608

G206



G1080



G1040

G1070
Opening



G1070



G1050



G1100





BLIND V

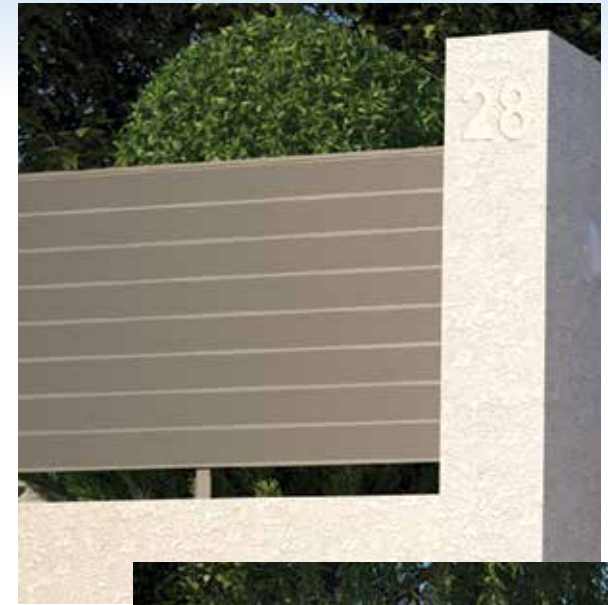

BLIND C



BLIND H





ΟΡΟΦΗΣ
UP-AND-OVER GARAGE DOORS
PORTE DE GARAGE
BASCULANTE

ΣΠΑΣΤΗ (ΤΑΜΠΛΑΔΩΤΗ)
SECTIONAL GARAGE DOORS
PORTE DE GARAGE
ACCORDÉON

ΡΟΛΟ
ROLLER GARAGE DOORS
PORTE DE GARAGE ROULANTE



ΑΝΟΔΙΩΜΕΝΑ ΚΑΓΚΕΛΑ
ANODIZED ALUMINUM RAILINGS
BARREAUX ANODISÉS



Accord

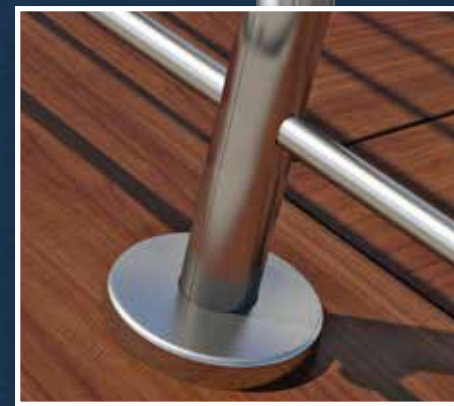
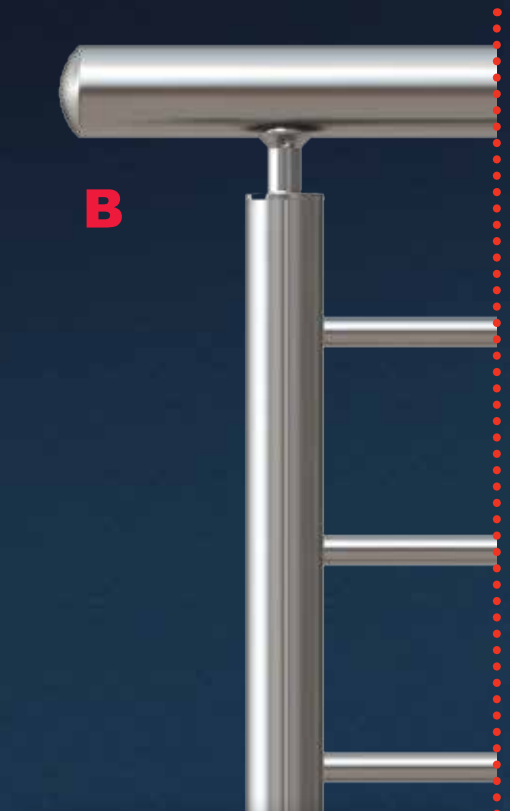
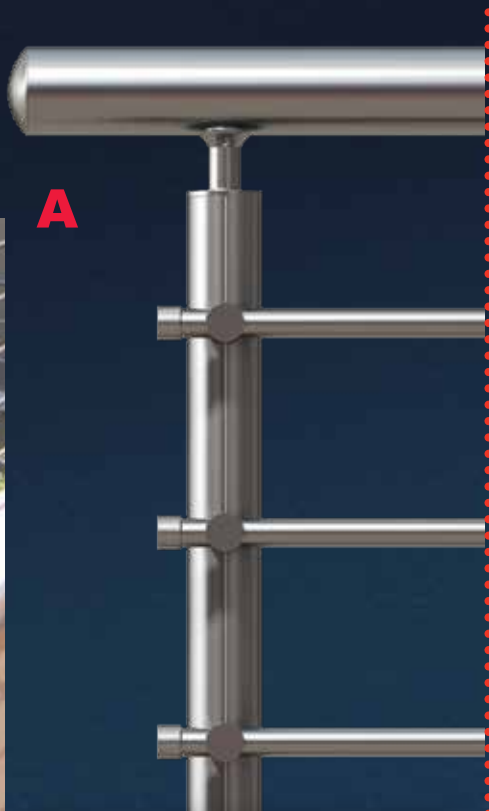

Tip! Να μην τοποθετείται σε χώρους που έχουν πρόσβαση μικρά παιδιά.
Do not install where small children can access it.
Ne convient pas aux lieux accessibles par des petits enfants.

Accord



Ειδικά σχεδιασμένα εξαρτήματα επιτρέπουν την εφαρμογή του σχεδίου Accord σε κάθε τύπο σκάλας, εσωτερική ή εξωτερική.

Specially designed components allow for implementation of the Accord design in any staircase type, whether interior or exterior

Des accessoires spécialement conçus permettent la pose du modèle Accord sur tout type d'escalier, intérieur ou extérieur.

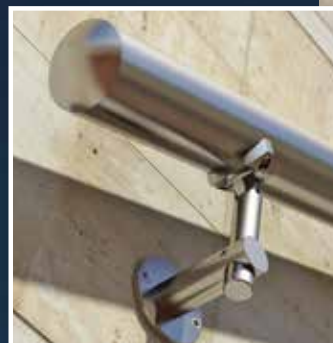

Accord

QUATTRO



Vertical-D

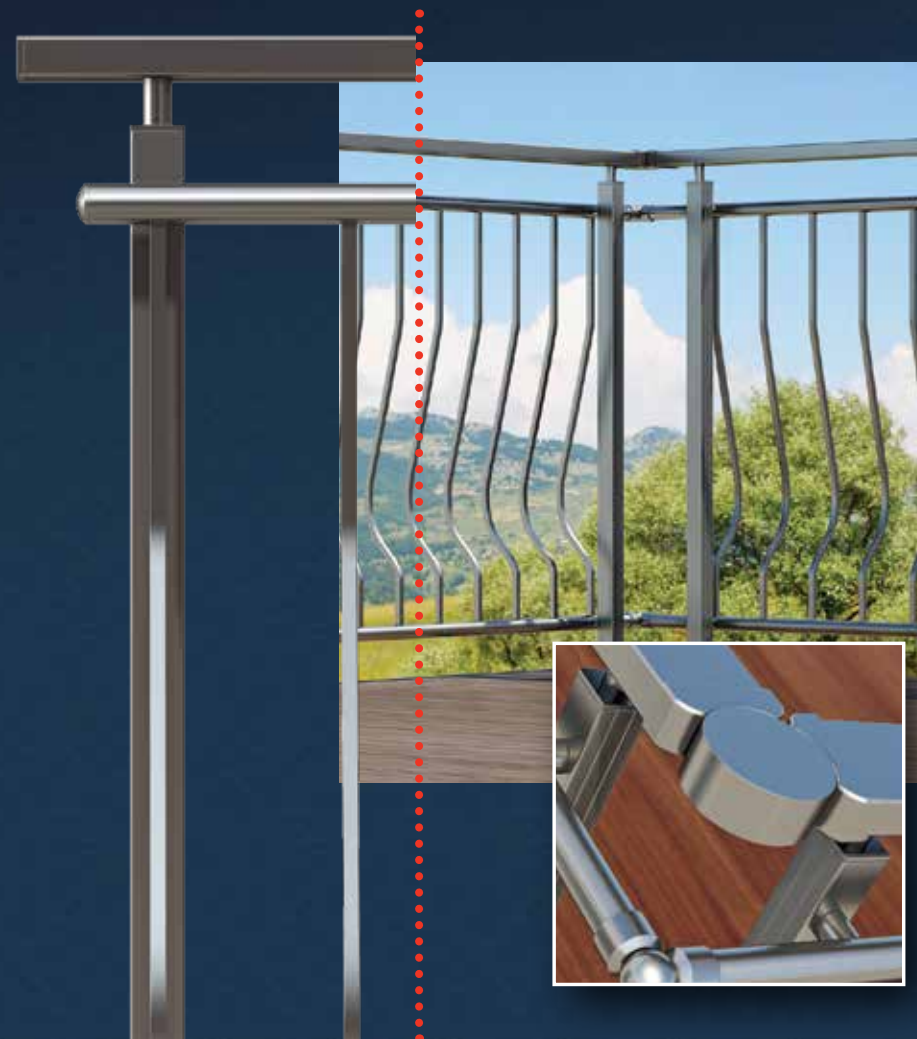
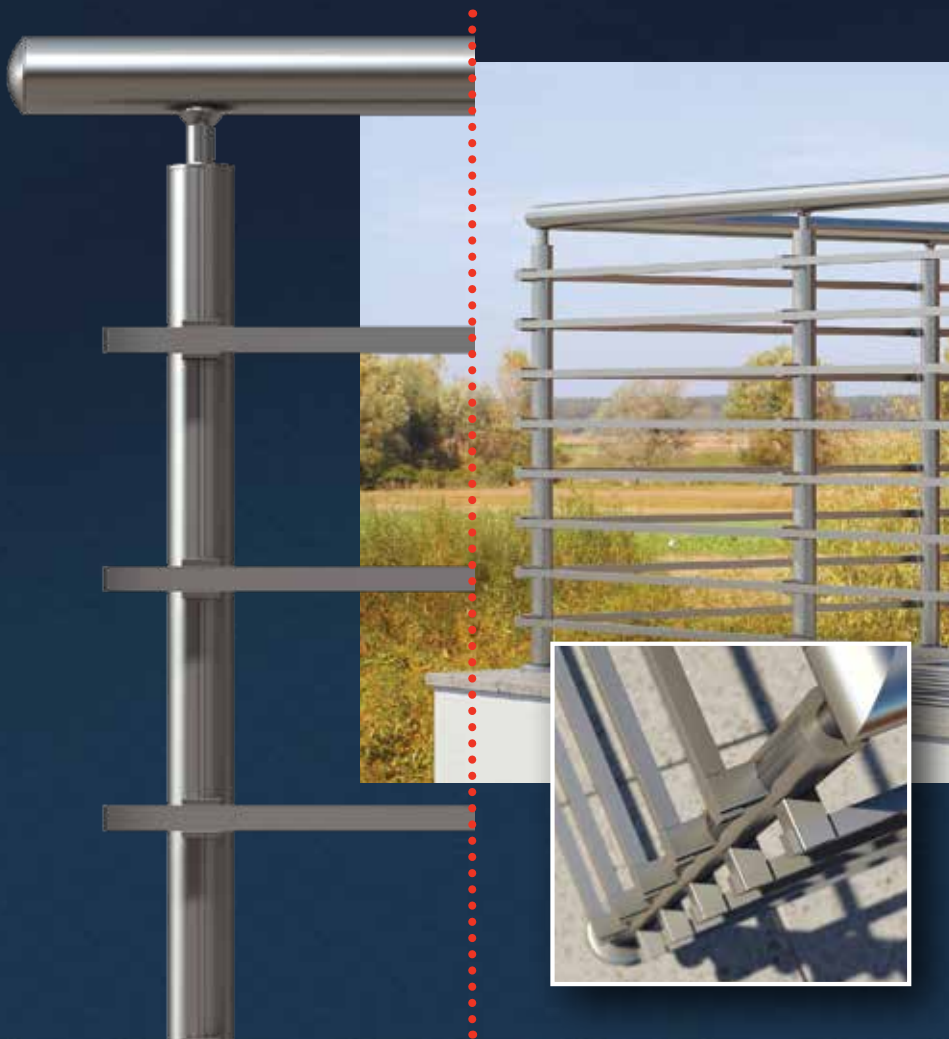

tip!

Να μην τοποθετείται σε χώρους που έχουν πρόσβαση μικρά παιδιά.
Do not install where small children can access it.
Ne convient pas aux lieux accessibles par des petits enfants.

Vertical-R



A

B

Vertical

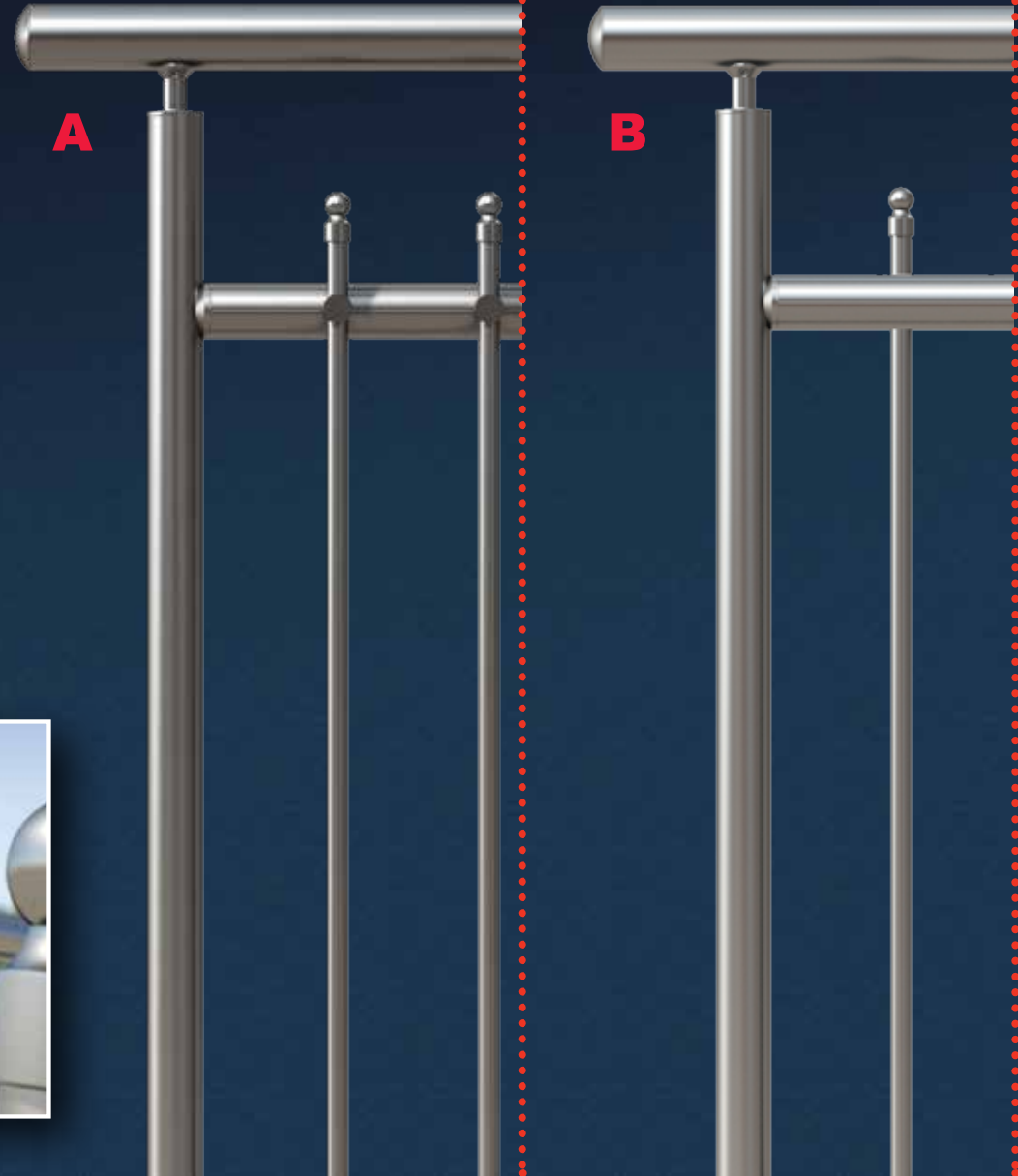

Horizon

BASIC

INOX 209 Colors
RAL
Διαθέσιμο φινιρίσμα
Finishing available
Finitions disponibles



Horizon

U-Rail

INOX 209 Colors
RAL
Διαθέσιμο φινιρίσμα
Finishing available
Finitions disponibles



Horizon

X-Rail

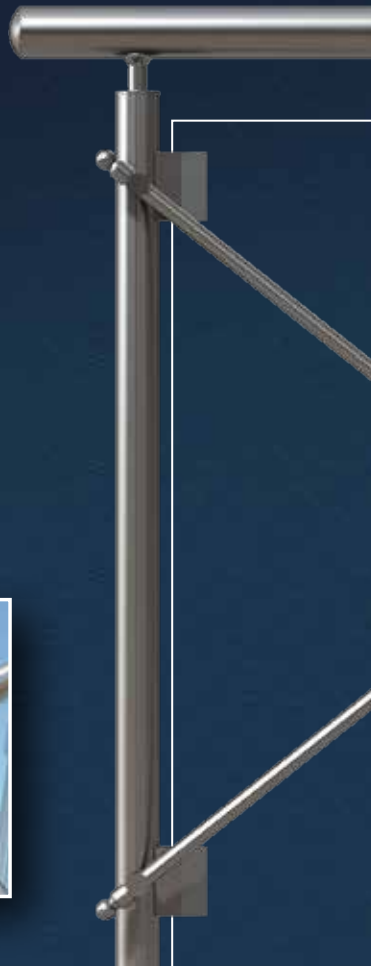

Horizon

X-Rail



Crystalline

railing system

Σειρά με κρύσταλλα για ανεμπόδιση θέα.
Μια μεγάλη γκάμα από βάσεις, ιδανικά για μπαλκόνια, σκάλες και περιφράξεις κτιρίων με υψηλές αρχιτεκτονικές απαιτήσεις. Προσφέρουν εντυπωσιακό αισθητικό και λειτουργικό αποτέλεσμα, χωρίς να περιορίζει την θέα.

A line with crystals for unobstructed view.
A wide range of bases, ideal for balconies, staircases and building fences meeting high architectural requirements. They offer an impressive result in terms of aesthetics and functionality without obstructing the view.

Une vaste gamme de supports, idéaux pour les balcons, escaliers et clôtures de bâtiments aux standards architecturaux élevés. Offrent un résultat esthétique remarquable, mais également très fonctionnel, sans limiter la vue.

SLIM LINE

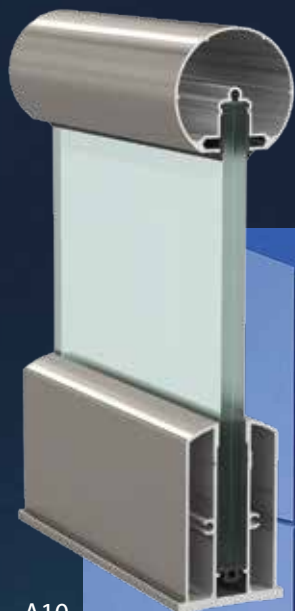

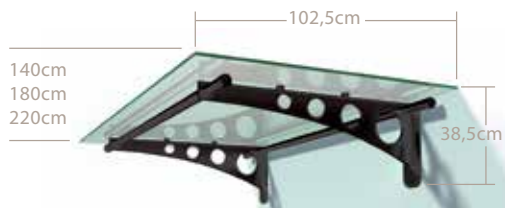

296



294



295



292



Τα στέγαστρα εισόδου αποτελούν την ιδανική λύση προστασίας των κυρίων εισόδων κατοικιών και επαγγελματικών χώρων από τη βροχή και την ηλιακή ακτινοβολία. Δυνατότητα κάλυψης με συμπαγή πολυκαρμπονικά και ακρυλικά φύλλα.

Entrance door awnings are the ideal solution for protection of the main entrances of residence and office buildings against the rain and solar radiation. They can be covered with compact polycarbonate and acrylic sheets.

Les marquises pour porte d'entrée constituent la solution idéale de protection contre la pluie et le rayonnement solaire des entrées principales de maisons et de bâtiments de bureaux. Couverture en polycarbonate dense ou feuilles d'acrylique.



397

Η παραδοσιακή πέργκολα μπορεί να εφαρμοσθεί σε κατασκευές κτιρίων προσδίδοντας την αίσθηση του κλασικού.

Η βαφή της πέργκολας αλουμινίου γίνεται ηλεκτροστατικά με ειδική επεξεργασία sea side class για προστασία από την αρμύρα και διατίθεται σε πολλά χρώματα καθώς επίσης σε αποχρώσεις απομίμησης ξύλου.

The traditional pergola can be used in building constructions giving them a sense of classic style. Aluminum pergolas are coated with electrostatic paint in many colors as well as faux wood colors using a special Sea Side Class treatment for protection against salt.

La pergola traditionnelle peut être posée sur tout bâtiment, lui conférant une esthétique classique. Le laquage de la pergola en aluminium est réalisé par traitement électrostatique seaside class, pour une protection contre l'eau de mer, et offre une large gamme de couleurs ou de teintes imitation bois.

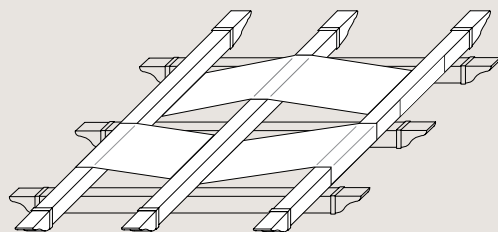
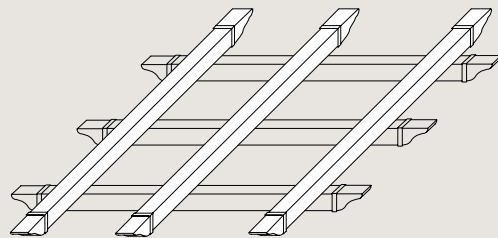

 **NYFAN**
 **TENCATE**



Σύστημα
στήριξης
οροφής

Roof
support
system

Système
de support
de toit



Η παραδοσιακή πέργκολα μπορεί να δεχθεί πολυκαρμπονικά φύλλα που προσφέρουν επιπλέον προστασία από τις διάφορες καιρικές συνθήκες. Αισθητικά προσδίδει την αριστοκρατική τεχνοτροπία του νεοκλασικού.

The traditional pergola can be covered with polycarbonate sheets that offer extra protection against various weather conditions. From an aesthetic point of view, it gives a building the aristocratic style of neoclassicism.

La pergola traditionnelle peut être recouverte de feuilles de polycarbonate, qui offrent une protection supplémentaire contre les intempéries. Pour une mise en valeur du style aristocratique néoclassique.

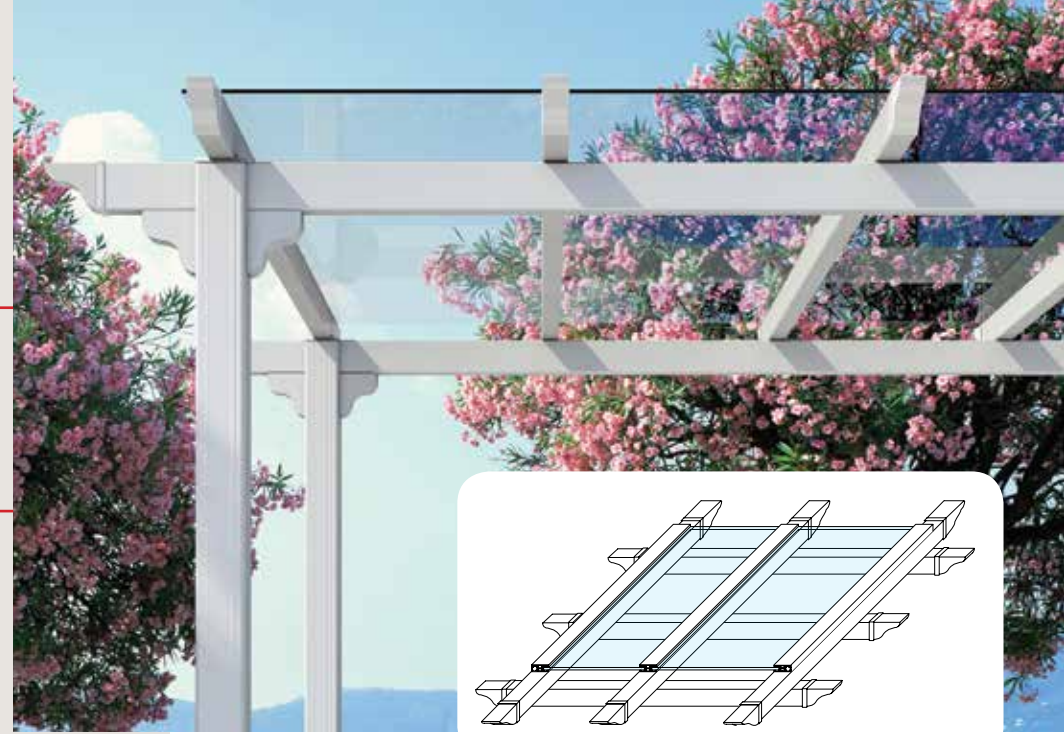

Δυνατότητα χρήσης ηλεκτρικού μοτέρ

Capability of using an electric motor

Possibilité d'intégrer un moteur électrique



Πέργκολα με κινούμενες περσίδες

Η τεχνολογική εξέλιξη στα συστήματα σκίασης! Μια εξαιρετικά μοντέρνα λύση που έγινε με δύο παράλληλους γνώμονες, τη λειτουργικότητα και την υψηλή αισθητική. Με τη χρήση ενός μοτέρ, η πέργκολα προσφέρει σκίαση όσο και όποτε το επιθυμείτε, ρυθμίζοντας απλά την κλίση των προφίλ της οροφής. Προσφέρει μια νέα αισθητική, αναδιαμορφώνοντας συνολικά ένα χώρο, έχοντας πλήρη εναρμόνιση με την αρχιτεκτονική του κτιρίου στο οποίο εφαρμόζεται.

Pergola with movable blinds

The technological advance in shading systems! An extremely modern solution, which was developed with two things in mind: functionality and high aesthetics. Using an electric motor, the pergola offers shading whenever and for as long as you wish; all you have to do is adjust the inclination of the roof profiles. It provides a new style, since it reshapes an area but remains in full harmony with the architecture of the building it is applied in.

Pergola à vantaux mobiles

Les derniers progrès technologiques pour les systèmes d'ombrage! Une solution extrêmement moderne, conçue pour allier fonctionnalité et esthétique. Grâce à son moteur, la pergola offre un ombrage entièrement adapté à votre demande, par le simple réglage de l'inclinaison du profilé du toit. Offre un style nouveau, redéfinissant l'espace dans son entier, en totale harmonie avec l'architecture du bâtiment auquel elle s'applique.

Πρωτοποριακός σχεδιασμός υδρορροής

Innovative gutter design

Conception innovatrice d'évacuation des eaux de pluie

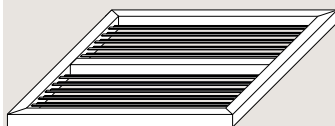

Η Πέργκολα NYFAN Jumbo είναι ένα πτυσσόμενο σύστημα βαρέως τύπου αλουμινίου και επιφάνειας PVC για κάλυψη εξωτερικού χώρου. Προτείνεται ιδιαίτερα για μεγάλες κατασκευές. Κατοικίες και για επαγγελματικούς χώρους. Παρέχει ηλιοπροστασία, καθώς και προστασία από τον άνεμο την βροχή και μερικώς από το χιόνι. Σωστά τοποθετημένη με την κατάλληλη κλίση, μπορεί να αντέξει ισχύ ανέμου έως και 11 Beauforts.

Pergola NYFAN JUMBO is a heavy duty movable ceiling system made up of aluminium and PVC fabric for outdoor protection. It is specially designed for Large Scale Constructions and Commercial Outdoor Spaces. It provides sun, wind, rain and partial snow protection. Properly Installed and with the correct inclination, it can stand wind forces up to 11 Beauforts.





Οβάλ περσίδα
Oval blind
Vantail oval



Ίσια περσίδα
Straight blind
Vantail droit

Η φινέτσα συναντά την ποιότητα. Μια ακόμα λύση μοντέρνας πέργκολας όπου οι περσίδες μπορεί να χρησιμοποιηθούν σε ορισμένα τμήματα, δημιουργώντας ευφάνταστους συνδυασμούς πρωτότυπων κατασκευών. Αποτελούν την τέλεια αρχιτεκτονική λύση για μια νέα και προοδευτική σχεδίαση στο χώρο.

Finesse meets quality. Another modern pergola solution, where the blinds can be used in certain sections only, creating imaginative combinations for original constructions. They are the perfect architectural solution for new and progressive area planning.

Lorsque la finesse rencontre la qualité. Là aussi une solution moderne, où les vantaux peuvent être utilisés dans certaines parties, offrant la possibilité de combinaisons imaginatives à partir de la construction originale. La solution architecturale parfaite pour une réorganisation innovatrice de l'espace.

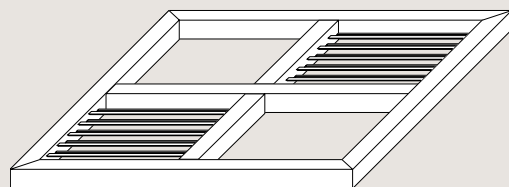

Φωτιστικά / Lightings / Luminaires



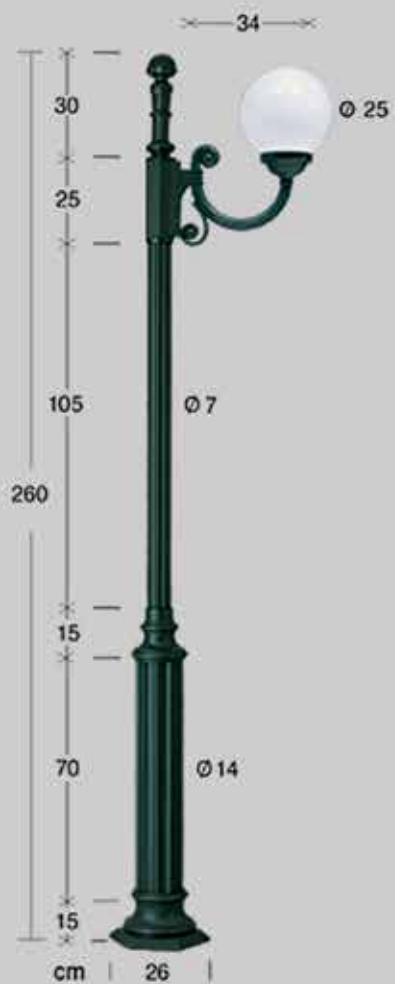

Z E U S



Z E U S



5018



C R O N O S



C R O N O S



5067



5068



PIRSOS

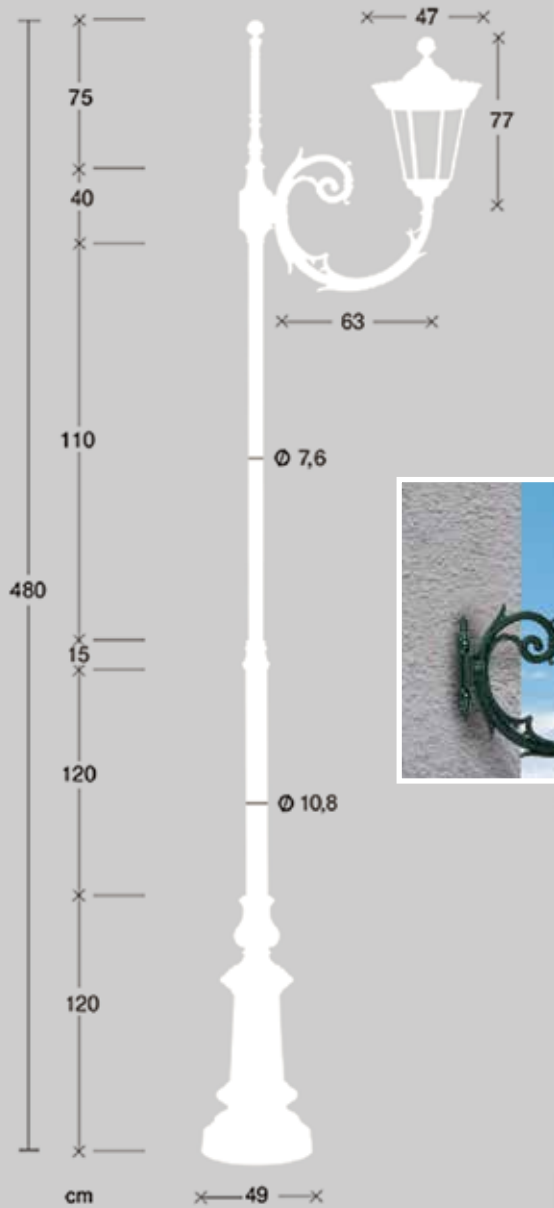

PEGASUS



5066



PIROFANI



5069

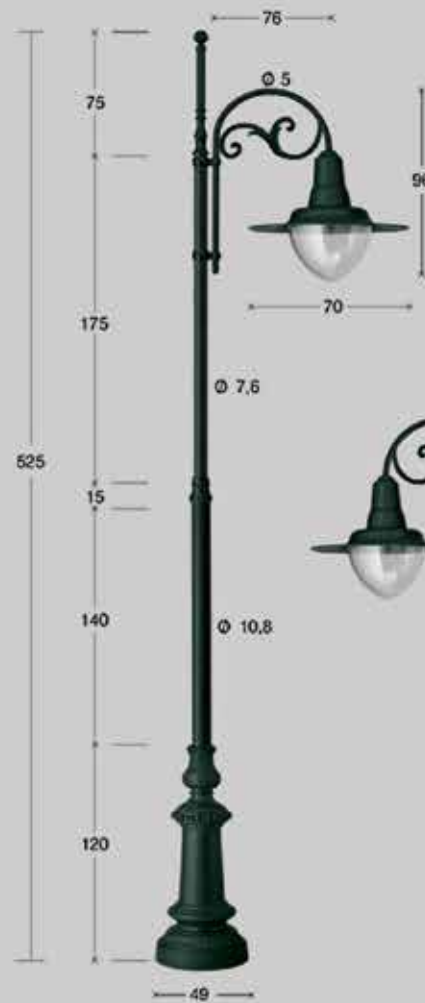

CARAVOLO



ΚΟΥΦΩΜΑΤΑ / FRAMES / FENÊTRES



Ο προσεγμένος σχεδιασμός των κουφωμάτων αλουμινίου gp, σε συνδυασμό με τα ειδικά εξαρτήματα και τις υψηλές προδιαγραφές κατασκευής, οδηγούν στην παραγωγή κουφωμάτων που ανταποκρίνονται σε αυστηρά κριτήρια ποιότητας.

Τα ευέλικτα συστήματα σε συνδυασμό με την τεχνογνωσία μας, σας προσφέρουν στιβαρές κατασκευές κατάλληλες για μεγάλα ανοίγματα, έως και 10 μέτρων!

Τα κουφώματα που θα επιλέξετε, θα σας ανταμείψουν με αισθητή εξοικονόμηση ενέργειας και χρημάτων, ηχομόνωση, στεγανότητα, αντοχή στις καταπονήσεις και ασφάλεια.

The careful design of the gp aluminum frames, in combination with the special components and the high manufacturing standards, leads to the production of frames that conform to strict quality criteria.

The versatile systems, combined with our know-how, provide you with robust constructions that are suitable for large openings up to 10 meters wide!

The frames you will choose will save you energy and money and provide you with sound insulation, water-tightness, strength and safety, rewarding you for your choice.

La conception soignée des fenêtres aluminium gp, alliée à des accessoires spécifiques et à des normes de construction, conduisent à la production de fenêtres répondant à de stricts critères de qualité.

La flexibilité de nos systèmes, combinés à notre savoir-faire, vous offrent des produits robustes, adaptés aux grandes ouvertures, jusqu'à 10 mètres !

Les fenêtres que vous choisirez vous offriront en retour de sensibles économies d'énergie, et donc d'argent, isolation sonore, étanchéité, résistance aux tensions et sécurité.



Θερμομονωτικά κουφώματα
Πρωτοποριακά ενεργειακά
κουφώματα υψηλών
επιδόσεων, ιδανικά και για
αντικατάσταση παλαιών.

Δυνατότητα επιλογής
διαφορετικού χρωματισμού
μέσα και έξω

(570) $U_w=1,4W/m^2K$

*Ο συντελεστής θερμομόνωσης έχει υπολογιστεί για κατασκευή 220,0x90,0 με $U_g=0.8$ 3+3/16(ARGON)/4 της AGC

Thermally insulated frames
Innovative energy- efficient
high- performance frames,
ideal for the replacement of
your old ones.

Available with different colors
on each side.

(570) $U_w=1.4W/m^2K$

* The thermal insulation factor has been calculated for a construction 220.0x90.0 with $U_g=0.8$ 3+3/16(ARGON)/4 by AGC

Fenêtres à isolation thermique
Fenêtres innovatrices dotées
de performances énergétiques
élevées, également idéales
pour remplacer vos anciennes
fenêtres.

Choix de coloris différents intérieur/extérieur.

(570) $U_w=1,4W/m^2K$

*Coefficient d'isolation thermique calculé pour un article de 220,0x90,0 avec $U_g=0.8$ 3+3/16(ARGON)/4 d'AGC

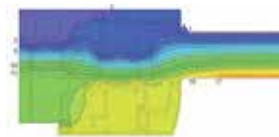
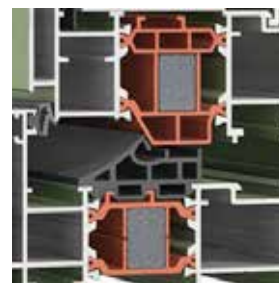



CRETE

ΠΙΚΡΑΚΗΣ ΑΕ ALUMINIUM INDUSTRY

Μάνου Κατράκη 60, Βιοτεχνικό πάρκο Φοινικιάς
Ηράκλειο Κρήτης ΤΚ 71410
Τηλ. 2810 312270, 2810 310004
Fax. 2810 260235
email. info@pikrakis.com.gr
www.pikrakis.com.gr

ΠΙΚΡΑΚΗΣ ΣΑ ALUMINIUM INDUSTRY

60 Manou Katraki str, Industrial Park of Finikia
Iraklion Crete Greece P.C. 71410
Tel. +30 2810 312270, +30 2810 310004
Fax. +30 2810 260235
email. info@pikrakis.com.gr
www.pikrakis.com.gr

TRINIDAD

SAVVAS KOUKOUNARAKIS,

12 Windsor Road Valsayn North ,
(868) 3986163

ΕΚΔΟΣΗ EDITION
ΙΑΝΟΥΑΡΙΟΣ
JANUARY **2020**



www.pikrakis.com.gr